



Chiltern House Stocking Lane Hughenden Valley
High Wycombe Buckinghamshire HP14 4ND UK

t +44 (0) 1494 569 800 f +44 (0) 1494 564895
e cif@chilternfire.co.uk w www.chilternfire.co.uk

CONFIDENTIAL

Test Report : Chilt/RF06118

**A fire resistance test performed on two single
leaf single acting doorsets**

**Test conducted in accordance with BSEN 1634-1: 2000
and BSEN 1363-1: 1999**

Test Date: 30 October 2006

Test for :
Astra Door Controls Ltd
Astra Business Centre
Roman Way
Preston
PR2 5AP

Page 1 of 25

Notified laboratory number 1314

Opinions and interpretations expressed herein are outside the scope of UKAS accreditation

This document is confidential and remains the property of Chiltern International Fire Ltd

The legal validity of this report can only be claimed on the presentation of the complete report.

This is an electronic copy of the report which is uncontrolled if printed.



No. 1762

Contents

	Page No
1 Introduction	3
2 Specimen verification	3
3 Description of supporting construction	3
4 Description of specimen	3
4.1 Door leaves	3
5 Pre-test measurements	4
5.1 Pre-cycling	4
5.2 Door perimeter gaps.....	4
5.3 Closer forces	4
5.4 Method of installation.....	4
6 Test conditions.....	4
6.1 Ambient temperature	4
6.2 Pressure readings.....	5
6.3 Furnace temperature	5
6.4 Unexposed face temperatures	6
6.5 Radiation	7
6.6 Door distortion data	8
7 Observations	9
8 Expression of results.....	11
9 Limitations.....	12
Description of construction.....	13
Figure 1	16
Figure 2	17
Figure 3	18
Figure 4	19
Figure 5	20
Figure 6	21
Appendix.....	22

1 Introduction

Two doorsets were installed into a flexible supporting construction. The doors were pre-cycled before the fire test. They were instrumented with the standard set of thermocouples and were installed opening in towards the furnace.

2 Specimen verification

The hardware was delivered to Chiltern International Fire Ltd during October 2006 who subsequently further produced the specimens with respect to the following:

- Hardwood lippings
- Door frames
- Intumescent materials
- Door leaves

The component parts of the doorset were identified and, where appropriate, moisture content readings and density checks were performed on either the original specimen, or, samples provided by the sponsor. These details are outlined in the construction section of this report.

3 Description of supporting construction

The supporting construction comprised a British Gypsum steel stud partition built in accordance with Clause 7.2.2.4 of BSEN 1363: Part 1, for a flexible supporting construction. The vertical studs surrounding the apertures created for the doorsets incorporated a 67mm x 29mm softwood timber infill to facilitate the fixings for the specimens. The specimens tested were 30 and 60 minute products with an anticipated Category B performance, therefore intended fire resistance is 36 and 68 minutes respectively and three layers of Gypsum plasterboard type F are required. The supporting construction was only fixed on the horizontal edges, the vertical edges remained free.

4 Description of specimen

Details of the specimens are shown in Figures 1 to 6.

4.1 Door leaves

The left leaf was designated doorset A and measured 1980mm high x 830mm wide x 44mm thick. The right leaf was designated doorset B and measured 1980mm high x 755mm wide x 54mm thick.

5 Pre-test measurements

5.1 Pre-cycling

Operability test of 25 manual cycles was completed on each doorset in accordance with BSEN 14600, section 5.1.1.1. Specimen self closing of doorset, in accordance with BSEN 14600, section 5.1.1.3 was completed prior to test.

5.2 Door perimeter gaps

The manufacturer did not declare a working range so the doors were installed to open and close freely, maintaining gaps, where possible, to a range of 2-4mm. The gaps between the edge of the doors and frame were measured prior to test. A total of 24 readings were taken. The measurements (in mm) are given in Figure 5.

5.3 Closer forces

Measured in accordance with BSEN 1634-1: 2000 Section 10.1.3.

	Opening Force (Nm)
Doorset A	22 @ handle position
Doorset B	29 @ handle position

5.4 Method of installation

The doorsets were fixed into a pre-prepared opening. The details of the fixings and fire stopping between frame and supporting construction are outlined in the construction section and Figure 4. The exposed face of the doorset was flush with the exposed face of the supporting construction.

6 Test conditions

6.1 Ambient temperature

The ambient temperature of the test area at commencement of test was 19°C. The ambient temperature for the duration of the test has been recorded in the Appendix.

6.2 Pressure readings

After the first 5 minutes of the test, the furnace pressure was maintained at 0 ± 5 Pa and after 10 minutes was maintained at 0 ± 3 Pa with respect to atmosphere, at a point 0.5m from the notional floor level. (The pressure was measured at a position 1m above the notional floor level which equates to a recorded reading of +4.25 Pa to produce the desired 0 Pa at a position 0.5m lower down.) The pressure readings have been tabulated in the Appendix and are shown graphically below:

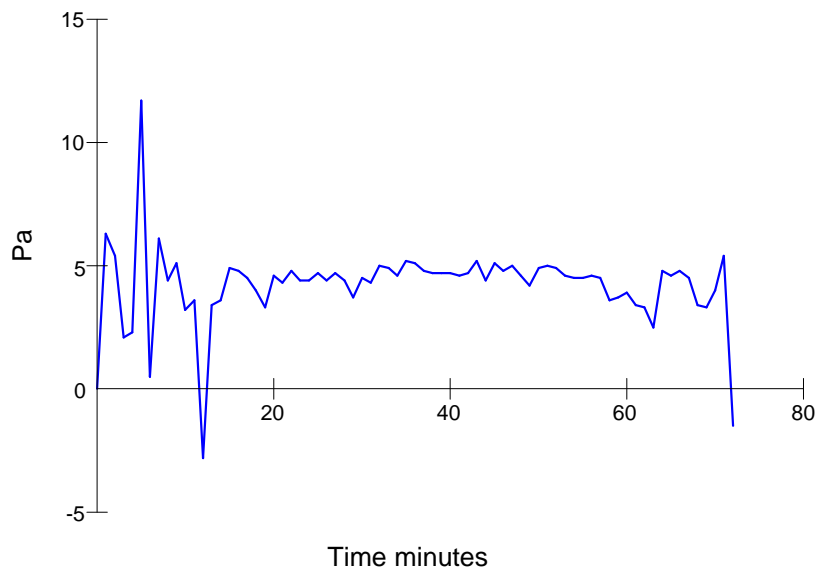

6.3 Furnace temperature

The furnace was controlled to follow the temperature/time relationship specified in BSEN 1363: Part 1: 1999 Section 5.1.1 as closely as possible, using the average of six plate thermometers suitably distributed within the furnace. The temperatures recorded have been tabulated in the Appendix and are shown graphically below:

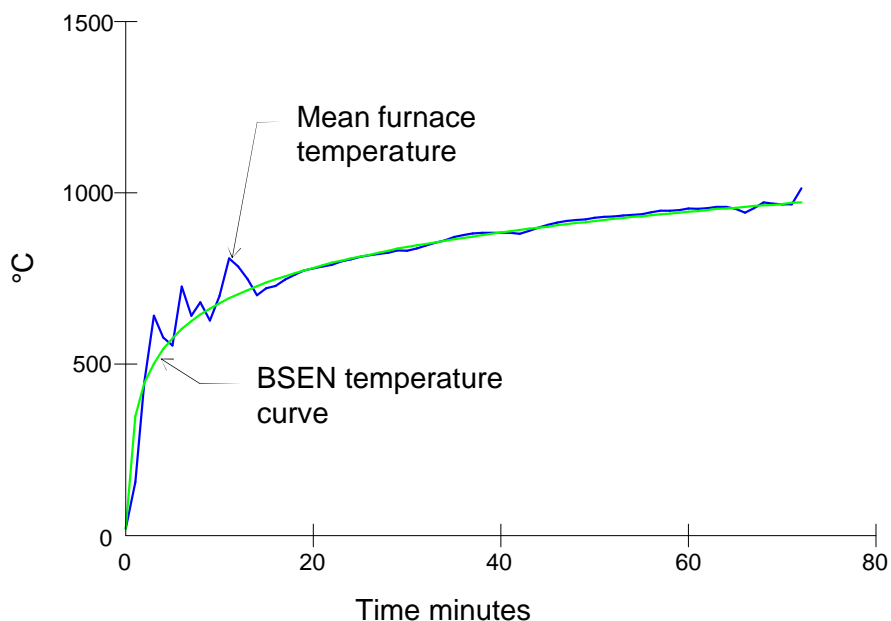

*The legal validity of this report can only be claimed on presentation of the complete report.
This is an electronic copy of the report which is uncontrolled if printed.*

6.4 Unexposed face temperatures

The temperature of the unexposed face was monitored by means of the following thermocouples:

Doorset A 1 discrete area

Leaf Discrete area 5 measuring mean temperature rise.
 1 (timber) 5 measuring maximum temperature rise, standard set
 100mm in from the door edge.

Frame 5 measuring maximum temperature rise.

Doorset B 1 discrete area

Leaf Discrete area 5 measuring mean temperature.
 1 (timber) 5 measuring maximum temperature rise, standard set
 100mm in from the door edge.

Frame 5 measuring maximum temperature rise.

The location of the thermocouples are shown in Figure 6. The temperatures recorded have been tabulated in the Appendix and are shown graphically below:

Doorset A

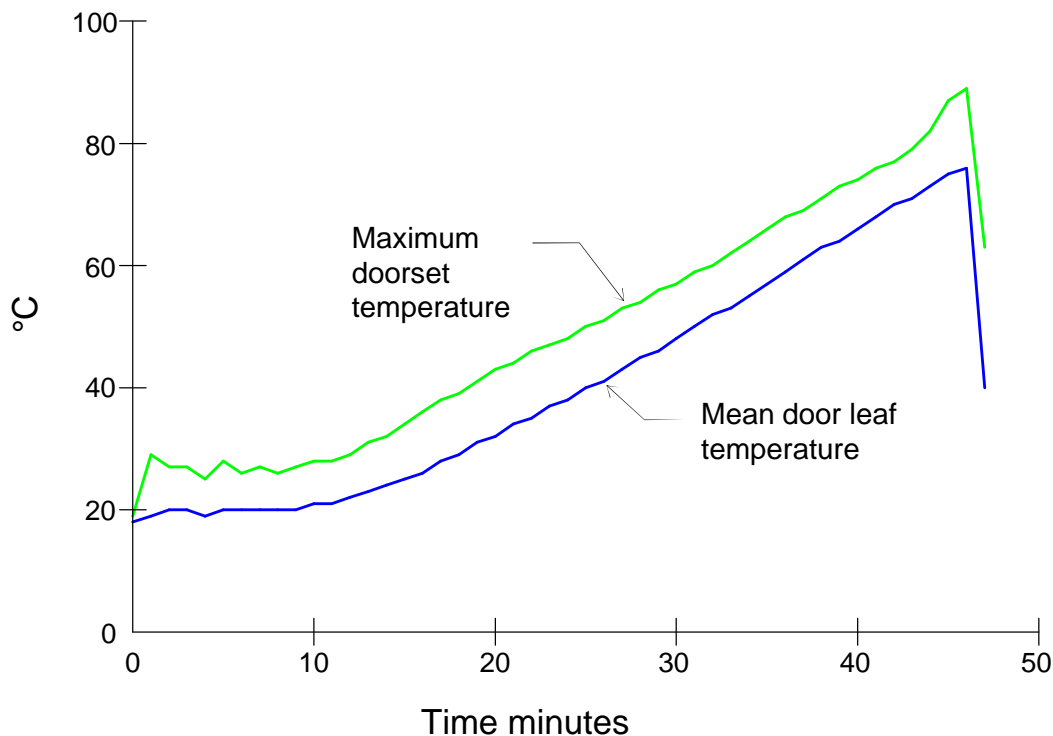

*The legal validity of this report can only be claimed on presentation of the complete report.
 This is an electronic copy of the report which is uncontrolled if printed.*

Doorset B

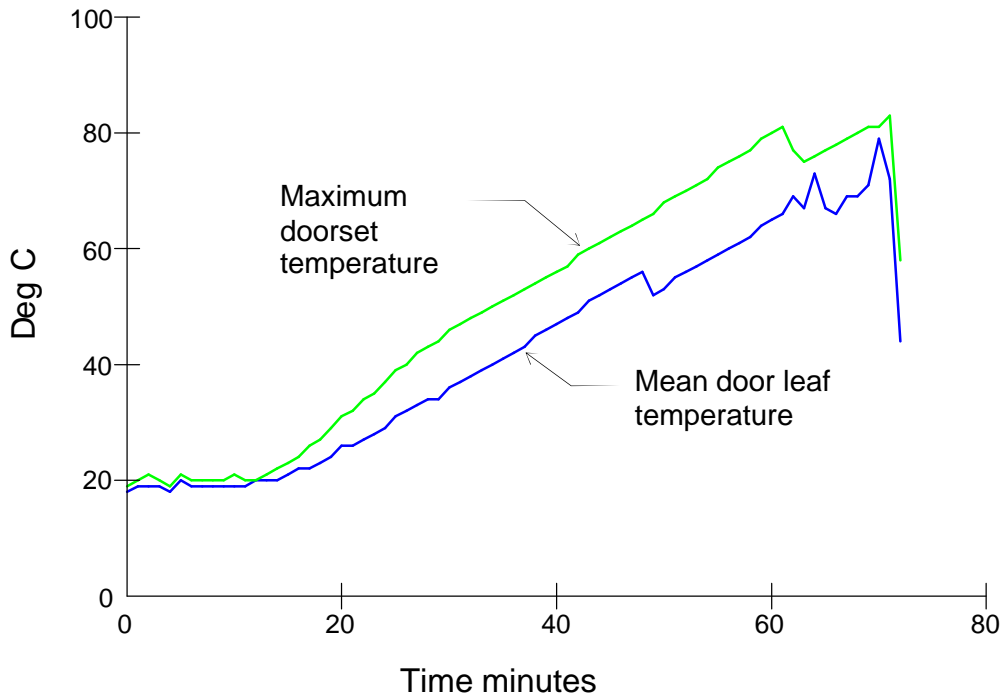

6.5 Radiation

A radiometer was used to measure the radiation 1m away from both doorsets.

The results of the radiometer have been tabulated and included in the Appendix and are shown graphically below for doorset A only (due to corrupt data a graph for doorset B could not be produced):

Doorset A

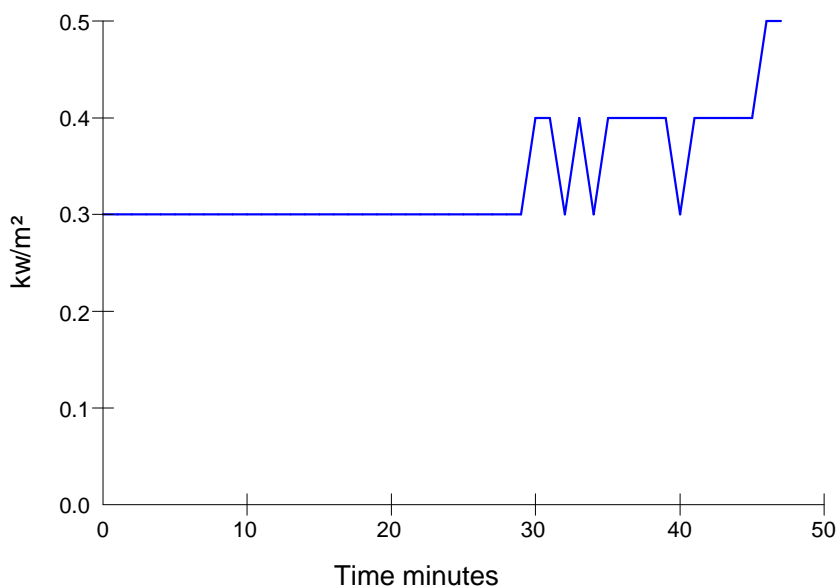

*The legal validity of this report can only be claimed on presentation of the complete report.
This is an electronic copy of the report which is uncontrolled if printed.*

6.6 Door distortion data

The following tables show the distortion of the doors in mm with an accuracy of ± 1 mm. A positive measurement indicates distortion towards the fire.

A negative measurement indicates distortion away from the fire.

J, K and L give vertical movement of the door, a negative reading indicates that the door has dropped.

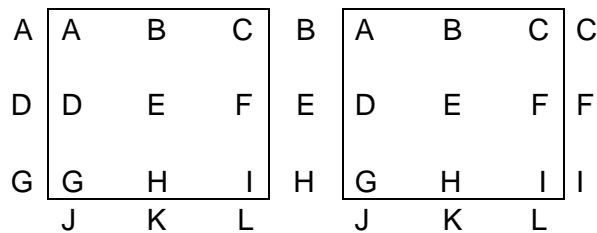

Doorset A (hung on the right and opening in towards the fire)

Time	A	B	C	D	E	F	G	H	I	J	K	L
10	10	7	10	3	0	3	5	3	4	-2	-1.5	-1
20	14	9	9	1	-1	3	7	2	4	-3	-2	-3
30	16	17	12	10	-5	13	6	-1	5	-4	-3.5	-3.5
40	20	5	10	-5	-15	0	8	-6	4	-5	-4	-4

Doorset B (hung on the right and opening in towards the fire)

Time	A	B	C	D	E	F	G	H	I	J	K	L
15	30	25	23	25	21	22	23	22	19	-1	-0.5	-0.5
30	13	6	5	1	-1	2	7	4	1	-2.5	-1	-1.5
45	10	0	5	-2	-4	-1	7	3	1	-4	-1	-2.5
60	17	5	10	-4	-6	4	15	4	6	-5	-3	-2.5

Partition

Time	A	B	C	D	E	F	G	H	I
15	5	5	-	5	3	3	2	1	0
30	5	5	1	4	3	1	-3	0	0
45	0	0	1	0	-5	0	-3	1	0
60	-	5	7	-	3	7	-	2	5

Where a dash (-) applies, a distortion reading could not be taken

7 Observations

All comments relate to the unexposed face unless otherwise specified.

Time (minutes)	Comments
00.00	Test started.
00.50	Both doorsets, there is smoke issuing from the latch position, middle hinge position, top closing and hanging corners of each leaf and across the head of the leaves.
04.30	Both doorsets, there is an increase in the level of smoke issuing from the bottom of the hanging and closing edges of each leaf.
05.40	Both doorsets, there is a decrease in the level of smoke issuing.
06.00	Both doorsets, there is an increase in the level of smoke issuing.
25.00	Doorset A, a temperature of 30°C was recorded at the closer positions.
25.30	Doorset A, there is a glow visible at the latch position.
30.00	Doorset A satisfactory.
33.47	Doorset A, a cotton pad integrity test was performed at the latch position, no failure.
36.18	Doorset A, a cotton pad integrity test was performed at the latch position, no failure.
36.50	Doorset A, there is a glow visible at the middle hinge position.
38.30	Doorset A, there is a glow visible at the bottom closer position.
44.00	Doorset A, a cotton pad integrity test was performed at the top closing corner of the leaf, no failure.
45.08	Doorset A, a cotton pad integrity test was performed at the top closing corner of the leaf which resulted in ignition of the cotton pad thereby constituting integrity failure .
54.13	Doorset B, there is burn through of the leaf at the top closer position approximately 260mm from the hanging edge.
58.06	Doorset B, a cotton pad integrity test was performed at the area of burn through at the top closing corner, approximately 260mm from the hanging edge, no failure.
59.49	Doorset B, there is a glow visible at the top hinge position and top closer position.

*The legal validity of this report can only be claimed on presentation of the complete report.
This is an electronic copy of the report which is uncontrolled if printed.*

- 60.00 Doorset B satisfactory.
- 61.04 Doorset B, a cotton pad integrity test was performed at the area of burn through which resulted in ignition of the cotton pad thereby constituting **integrity failure**.
- 61.30 Doorset B, there is continuous flaming from the area of burn through thereby constituting further **integrity failure**.
- 63.45 Doorset B, there is a glow visible at the latch position.
- 64.53 Doorset B, a cotton pad integrity test was performed at the top closer position, no failure.
- 66.29 Doorset B, a cotton pad integrity test was performed at the top hinge position, no failure.
- 68.30 Doorset B, there is a glow visible at the bottom hinge position.
- 69.02 Doorset B, there is intermittent flaming from the bottom closer position.
- 71.30 Test terminated.

8 Expression of results

Doorset A	Integrity	
	Cotton pad	45 (forty five) minutes
	Continuous flaming	* minutes
	Gap gauges	* minutes
	Insulation	* minutes - average set * minutes - standard set (max) * minutes - door frame (max)
	Radiation	* minutes to 15kW/m ²

Doorset B	Integrity	
	Cotton pad	61 (sixty one) minutes
	Continuous flaming	61 (sixty one) minutes
	Gap gauges	* minutes
	Insulation	* minutes - average set * minutes - standard set (max) * minutes - door frame (max)
	Radiation	* minutes to 15kW/m ²



* Failure criteria was not achieved prior to initial failure.

9 Limitations

The results only relate to the behaviour of the element of construction under the particular conditions of test; they are not intended to be the sole criteria for assessing the potential fire performance of the element in use nor do they reflect the actual behaviour in fires.

The results of this test were obtained using the door to frame gaps recorded in Figure 5. The fire resistance performance of doors of this design may change if substantially different gaps are employed.

The specification and interpretation of fire test methods are the subject of ongoing development and refinement. Changes in associated legislation may also occur. For these reasons it is recommended that the relevance of test reports over 5 years old should be considered by the user. CIFL will be able to offer, on behalf of the legal owner, a review of the procedures adopted for a particular test to ensure that they are consistent with current practices, and if required may endorse the test report.

Signature:		
Name:	Mark Cummings	Vincent Kerrigan
Title:	Senior Test Engineer	Deputy Technical Manager
Date of issue:		10 October 2007

*The legal validity of this report can only be claimed on presentation of the complete report.
This is an electronic copy of the report which is uncontrolled if printed.*

Description of construction (refers to Figures 1 to 6)

Leaf - doorset A

The leaf comprised a 44mm thick Halspan 30 minute doorblank (1). 6mm thick sapele lippings (2) were fixed to the vertical edges only using urea formaldehyde adhesive.

Leaf - doorset B

The leaf comprised a 54mm thick Halspan 60 minute doorblank (3). 6mm thick sapele lippings (4) were fixed to the vertical edges only using urea formaldehyde adhesive.

Door frame - doorset A

	Species/type	Dimensions (mm)	Density (kg/m ³)	Moisture (% w/w)	Key to figures
Head & jambs	European redwood	100 deep x 32 thick	510**	11-12	5
Stops	Integral	12 deep	510**	12	-
Architrave	European redwood	16 thick	510**	12-13	-
Threshold	Non combustible	-	-	-	-
Frame fixings	Steel wood screws at 6-800 centres	No 10 x 80 long	-	-	-
Frame fire stopping	Tightly packed mineral fibre capped off with intumescent mastic	Nominally 15 thick	-	-	-

* Stated density, not checked by laboratory ** Nominal density *** Measured density at 15% MC

Door frame - doorset B

	Species/type	Dimensions (mm)	Density (kg/m ³)	Moisture (% w/w)	Key to figures
Head & jambs	Sapele	70 deep x 32 thick	640**	13	6
Stops	Sapele - planted (pinned)	12 deep	640**	13	7
Architrave	Sapele	16 thick	640**	-	-
Threshold	Non combustible	-	-	-	-
Frame fixings	Steel wood screws at 4-600 centres	No 10 x 80 long	-	-	-
Frame fire stopping	Tightly packed mineral fibre capped off with intumescent mastic	Nominally 15 thick	-	-	-

* Stated density, not checked by laboratory ** Nominal density *** Measured density at 15% MC

*The legal validity of this report can only be claimed on presentation of the complete report.
This is an electronic copy of the report which is uncontrolled if printed.*

Intumescent materials - doorset A

		Make/type	Size (mm)	Location	Key to figures
Door edges		None fitted	-	-	-
Frame reveal	Head	Intumescent Seals Ltd Therm-A-Seal	20 x 4	Centrally fitted in the frame reveal	8
	Jambs	Intumescent Seals Ltd Therm-A-Seal	15 x 4	Centrally fitted in the frame reveal	9
Around hinges		Fully interrupted	-	Hinge blade fully interrupts the intumescent seal	-
Under hinge blade		Interdens	1 thick	Fitted under the blade on both leaf and frame	
Encasing latch body		None fitted	-	-	-
Under latch forend		None fitted	-	-	-
Under latch keep		None fitted	-	-	-
Closers		None fitted	-	-	-

Intumescent materials - doorset B

		Make/type	Size (mm)	Location	Key to figures
Door edges		None fitted	-	-	-
Frame reveal - head & jambs		2No Intumescent Seals Ltd Therm-A-Seal	15 x 4	Centrally fitted in the frame reveal spaced 10 apart	10
Around hinges		Partially interrupted	-	Hinge blade fully interrupts the first strip and partially interrupts the remaining seal with 12mm left running alongside the hinge blade	-
Under hinge blade		Intumescent Seals Ltd Therm-A-Strip	2 thick	Fitted under the hinge blade on both leaf and frame	-
Encasing latch body		Intumescent Seals Ltd Therm-A-Strip	2 thick	Wrapped around the latch body	-
Under latch forend		Intumescent Seals Ltd Therm-A-Strip	2 thick	Fitted under the latch forend	-
Under latch keep		Intumescent Seals Ltd Therm-A-Strip	2 thick	Fitted under the latch keep	-
Closers		Intumescent Seals Ltd Therm-A-Strip	2 thick	Fitted under the forend and closer body	

*The legal validity of this report can only be claimed on presentation of the complete report.
This is an electronic copy of the report which is uncontrolled if printed.*

Hardware - doorset A

	Make/type	Size (mm)	Location	Key to figures
Hinges	3No stainless steel bearing type hinges	101 high x 32 wide (blade size)	Fitted 150, 940 and 1730 from the head of the leaf	11
Closer A	Astra Door Controls ref: 3000 Series - engaged	64 high x 32 wide (forend size)	Fitted 430 from the head of the leaf	12
Closer B	Astra Door Controls ref: 1000 Series - disengaged	59 high x 31 wide (forend size)	Fitted 800 from the head of the leaf	13
Closer C	Gib Closer ref: C33 chain closer - disengaged	50 high x 23 wide (forend size)	Fitted 1150 from the head of the leaf	14
Closer D	Gibraltar closer - disengaged	115 x 30 (forend size)	Fitted to the exposed face as per manufacturer's specification	15
Latch	Standard tubular mortise latch - engaged	57 high x 26 wide (forend size)	Fitted 980 from the head of the leaf to the centre of the latch nib	16
Furniture	Aluminium lever type handles	100 x 38 (footprint size)	Fitted appropriate to the latch	17

Hardware - doorset B

	Make/type	Size (mm)	Location	Key to figures
Hinges	3No Royde & Tucker Hi load H101 lift off type hinges	100 high x 35 wide (blade size)	Fitted 150, 940 and 1730 from the head of the leaf	18
Closer E	Astra Door Controls ref: 3000 Series - engaged	64 high x 32 wide (forend size)	Fitted 432 from the head of the leaf	19
Closer F	Astra Door Controls ref: 1000 Series - disengaged	76 x 32 (forend size)	Fitted 1070 from the head of the leaf	20
Closer G	Astra Door Controls ref: 1000 Series - disengaged	76 x 32 (forend size)	Fitted 1400 from the head of the leaf	21
Closer H	Gibraltar closer - disengaged	115 x 30 (forend size)	Fitted to the exposed face as per manufacturer's specification	22
Latch	Standard tubular mortise latch - engaged	57 x 26 (forend size)	Fitted 980 from the head of the leaf to the centre of the latch nib	23
Furniture	Aluminium lever type handles	100 x 38 (footprint size)	Fitted appropriate to the latch	24

*The legal validity of this report can only be claimed on presentation of the complete report.
This is an electronic copy of the report which is uncontrolled if printed.*

Doorset A

Doorset B

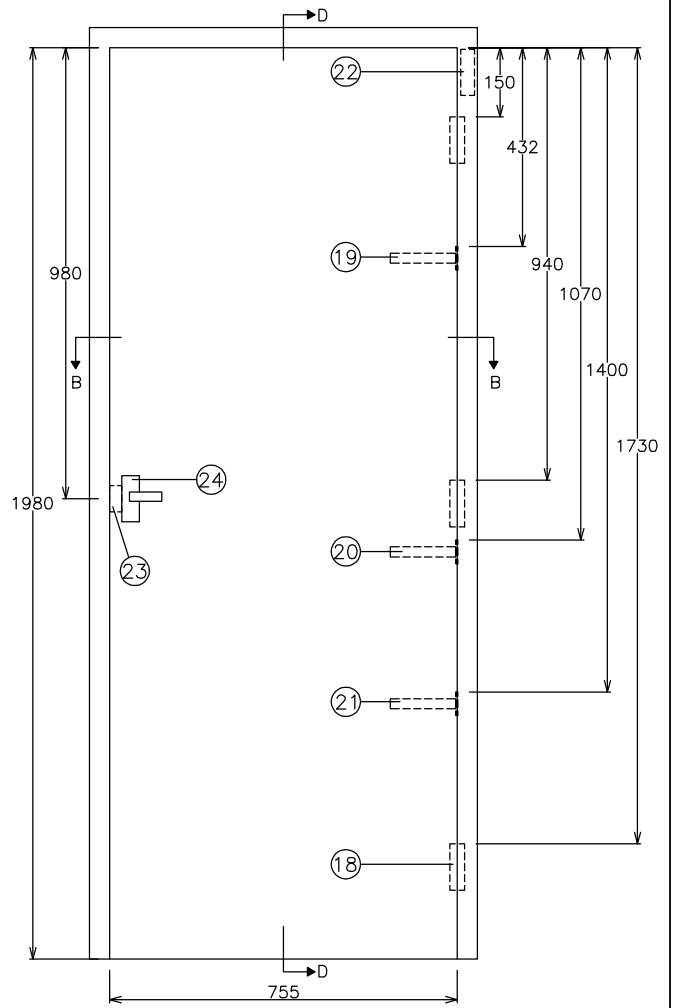
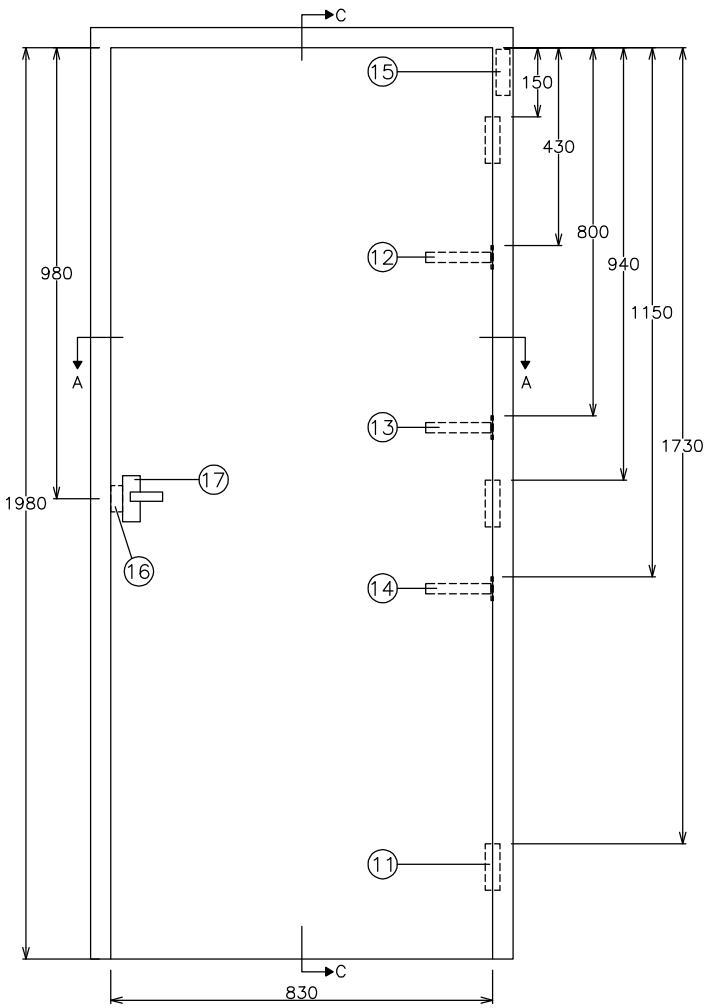

Chiltern House, Stocking Lane, Hughenden Valley
 High Wycombe, Buckinghamshire, HP14 4ND, UK.
 Tel: +44 (0)1494 569800 Fax: +44 (0)1494 564895

Title Unexposed face elevation showing ironmongery positions (All dimensions in mm)

Date Drawn 14/11/06	Drawn By SP	Scale NTS
Project No. Chilt/RF06118		Page 16 of 25

Section A-A

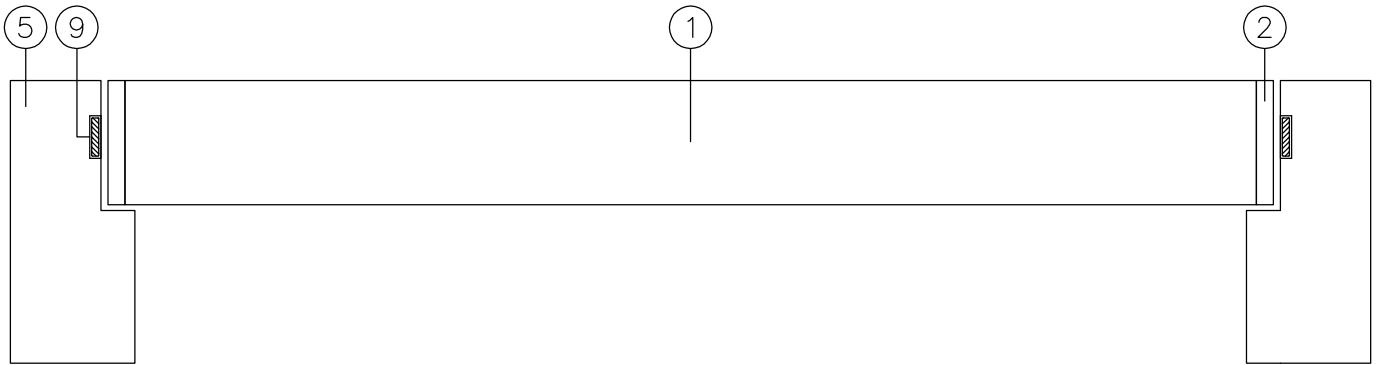

Section B-B

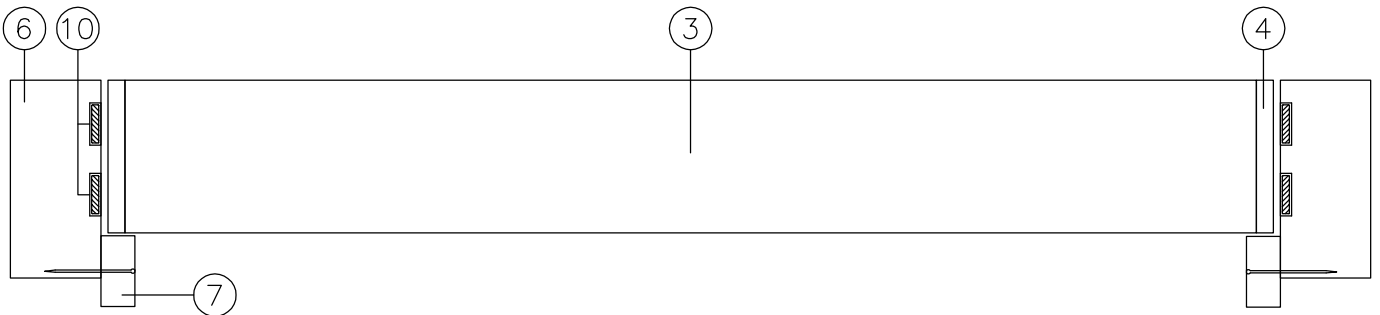

Chiltern House, Stocking Lane, Hughenden Valley
High Wycombe, Buckinghamshire, HP14 4ND, UK.
Tel: +44 (0)1494 569800 Fax: +44 (0)1494 564895

Title

Horizontal cross sections

Date Drawn

14/11/06

Drawn By

SP

Scale

NTS

Project No.

Chilt/RF06118

Page 17 of 25

Section C-C

Section D-D

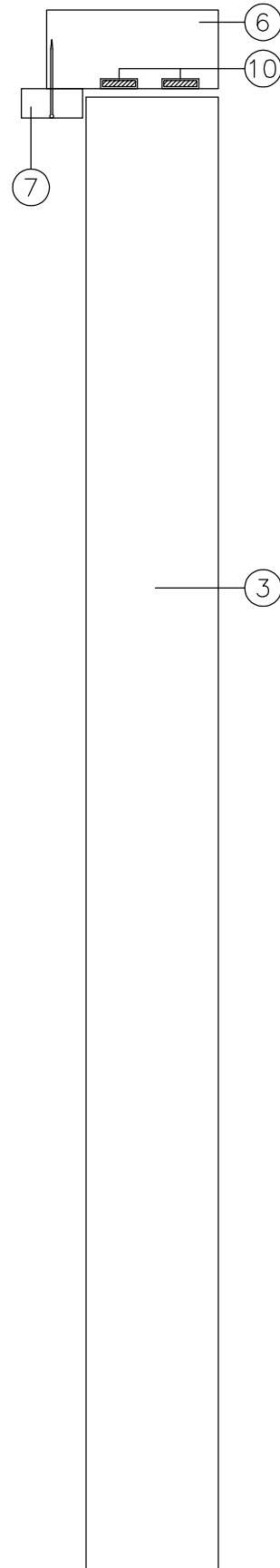
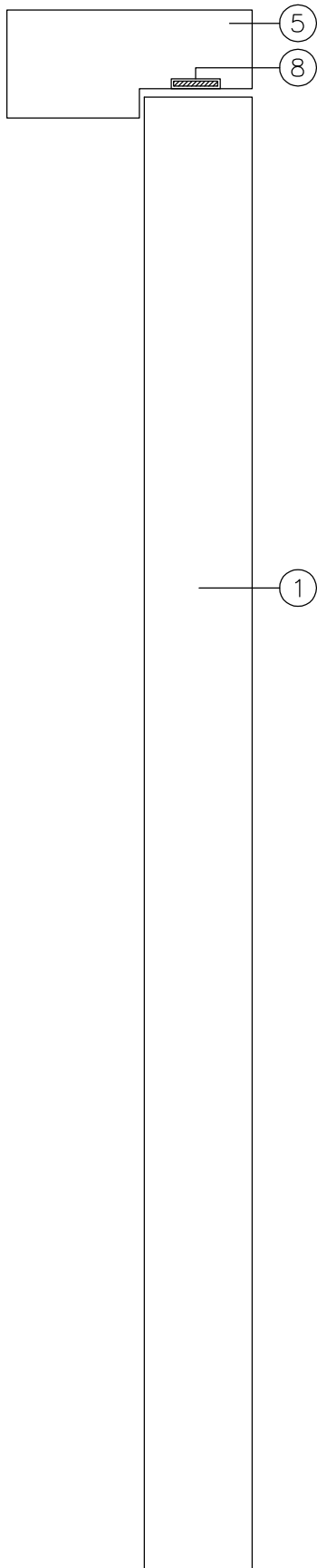

Chiltern House, Stocking Lane, Hughenden Valley
High Wycombe, Buckinghamshire, HP14 4ND, UK.
Tel: +44 (0)1494 569800 Fax: +44 (0)1494 564895

Title

Vertical cross sections

Date Drawn

14/11/06

Drawn By

SP

Scale

NTS

Project No.

Chilt/RF06118

Page 18 of 25

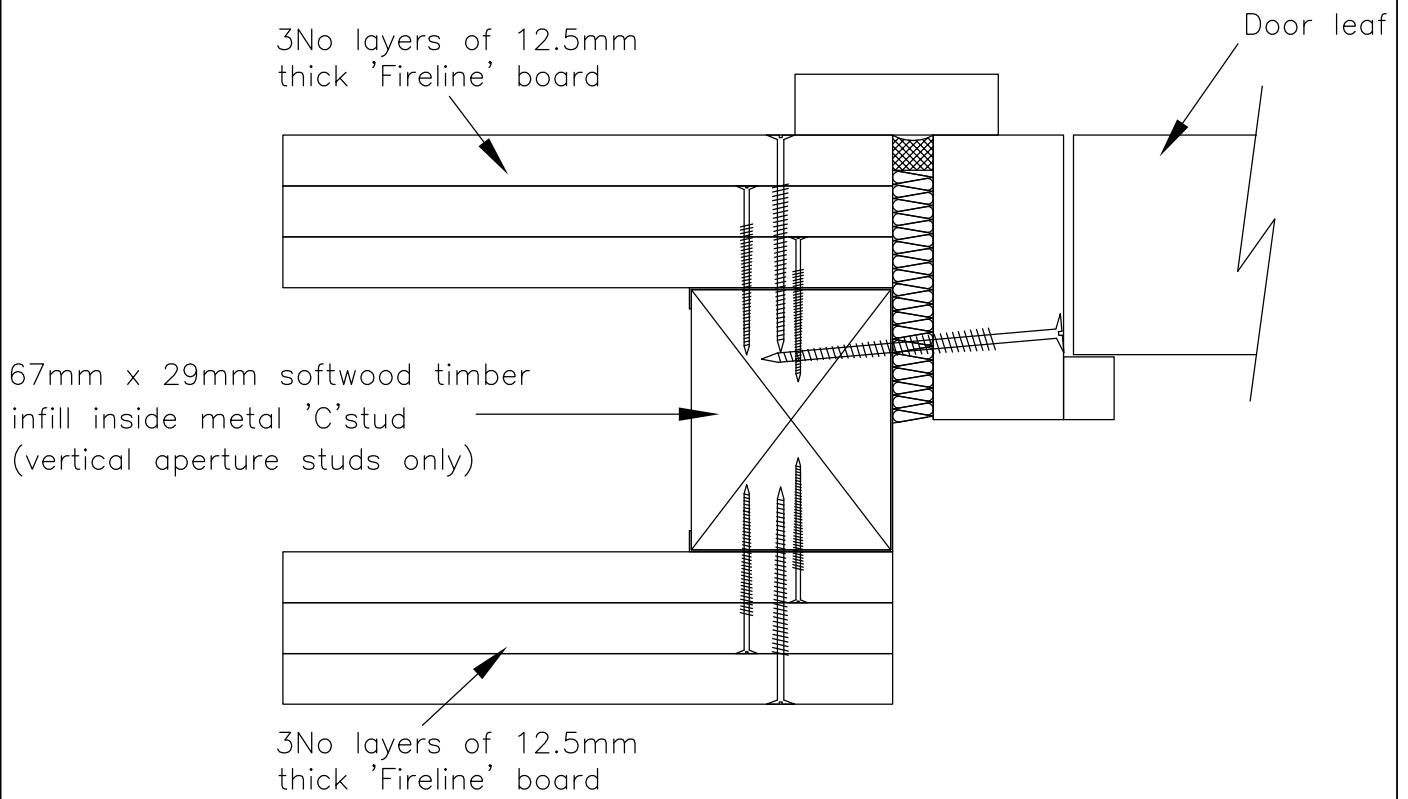

Chiltern House, Stocking Lane, Hughenden Valley
 High Wycombe, Buckinghamshire, HP14 4ND, UK.
 Tel: +44 (0)1494 569800 Fax: +44 (0)1494 564895

Title

60 minute flexible support

Date Drawn

14/11/06

Drawn By

SP

Scale

NTS

Project No.

Chilt/RF06118

Page 19 of 25

Doorset A

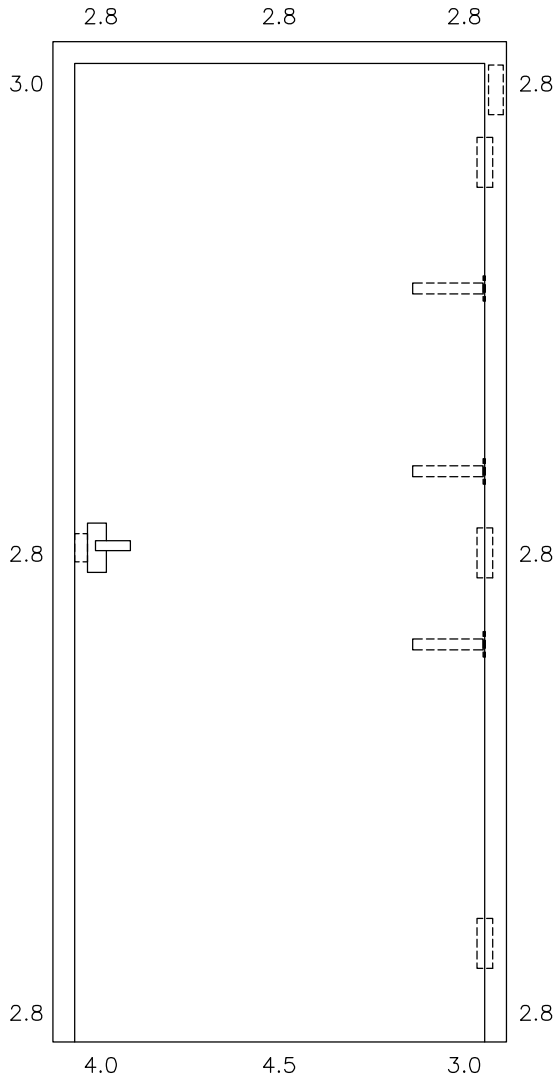

Doorset B

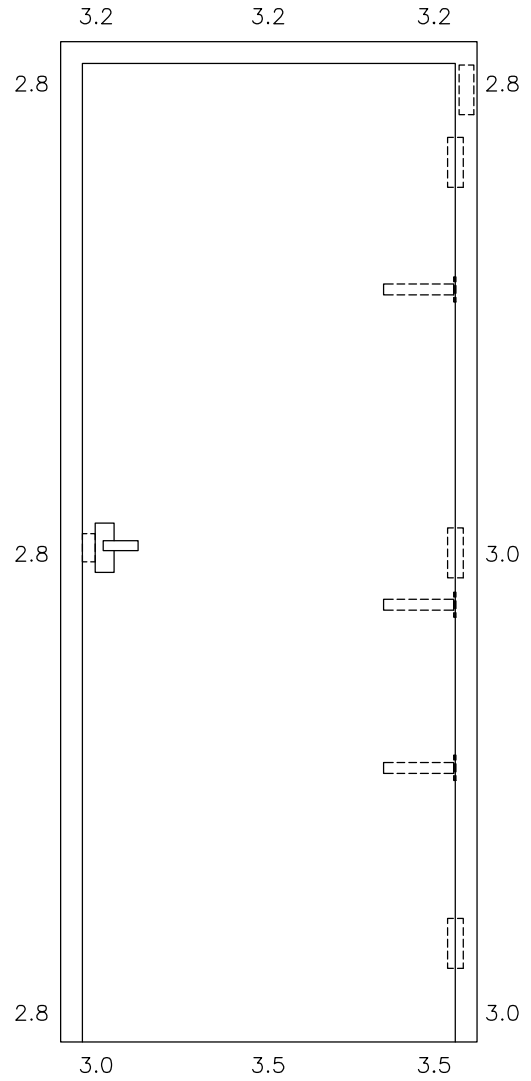

Chiltern House, Stocking Lane, Hughenden Valley
 High Wycombe, Buckinghamshire, HP14 4ND, UK.
 Tel: +44 (0)1494 569800 Fax: +44 (0)1494 564895

Title
 Door gaps
 (All dimensions in mm)

Date Drawn 14/11/06	Drawn By SP	Scale NTS
Project No. Chilt/RF06118		Page 20 of 25

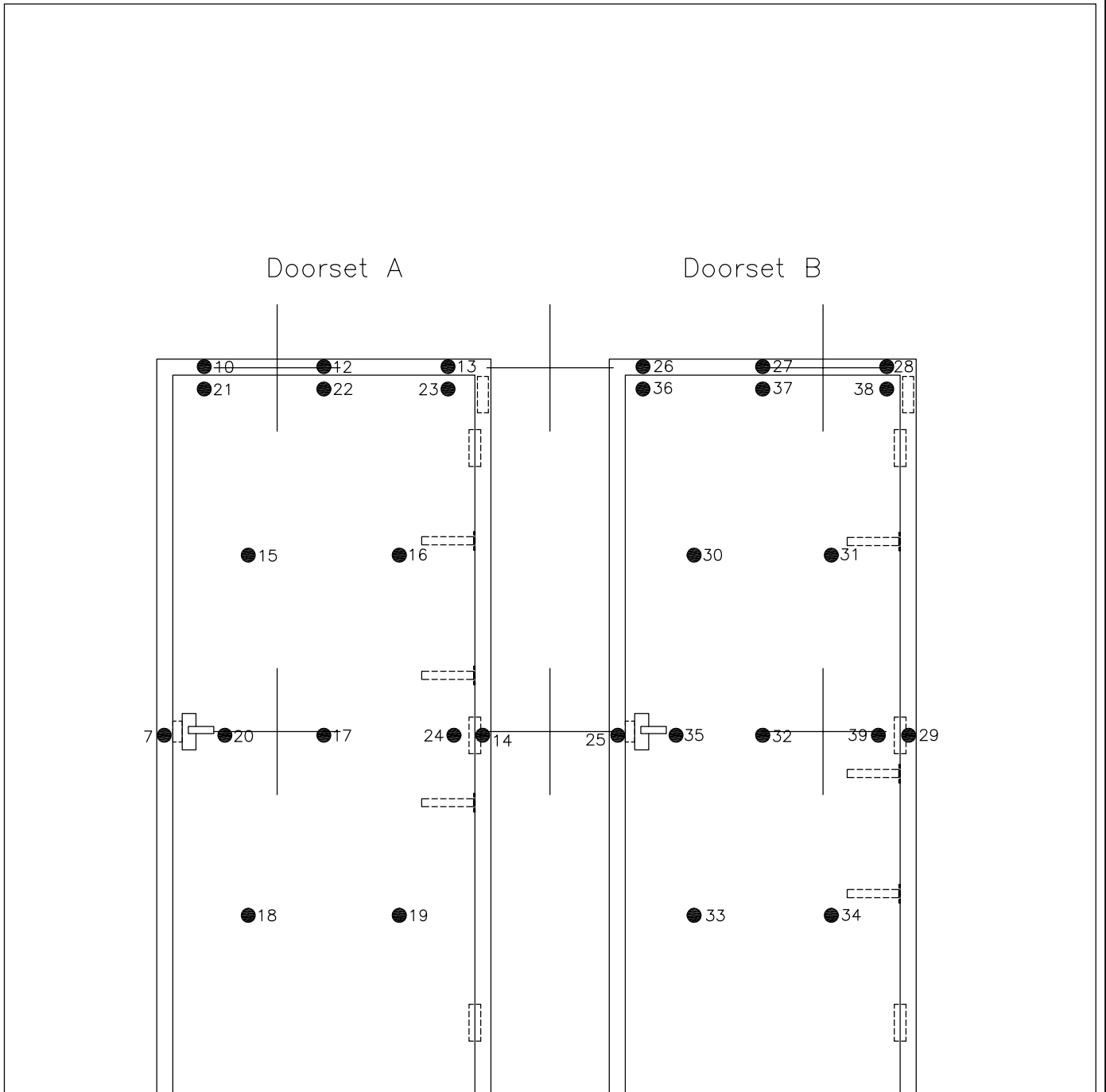

+ : Furnace Thermocouples
 ● : Unexposed Face Thermocouples

Gaps Shown

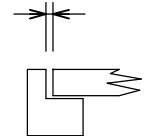

Viewed From Unexposed Face



Chiltern House, Stocking Lane, Hughenden Valley
 High Wycombe, Buckinghamshire, HP14 4ND, UK.
 Tel: +44 (0)1494 569800 Fax: +44 (0)1494 564895

Title
Thermocouple positions

Date Drawn 14/11/06	Drawn By SP	Scale NTS
Project No. Chilt/RF06118		Page 21 of 25



Appendix

Raw Test Data (see Figure 6 for channel locations)

Time	Chan 0	Chan 1	Chan 2	Chan 3	Chan 4	Chan 5	Chan 6	Chan 7	Chan 10	Chan 12	Chan 13	Chan 14	Chan 15	Chan 16	Chan 17	Chan 18	Chan 19	Chan 20	Chan 21	Chan 22	Chan 23	Chan 24	Chan 25	Chan 26	Chan 27	Chan 28	Chan 29	Chan 30	Chan 31
min	Pa	°C	°C	°C	°C	°C	°C	°C	°C	°C	°C	°C	°C	°C	°C	°C	°C	°C	°C	°C	°C	°C	°C	°C	°C	°C	°C	°C	°C
0	0	20	20	19	20	19	20	18	18	18	18	18	18	19	19	19	19	19	18	18	18	19	19	19	18	18	18	18	18
1	6.3	155	213	131	163	146	127	19	19	21	20	19	21	20	20	19	19	24	23	22	29	20	20	19	19	19	18	20	18
2	5.4	417	543	403	465	464	400	22	24	24	25	20	23	21	20	19	19	27	26	22	27	20	26	25	21	23	19	21	19
3	2.1	618	687	601	646	680	620	22	32	27	27	20	21	21	20	19	22	25	27	21	26	20	26	30	25	28	18	20	19
4	2.3	570	582	579	581	583	573	21	32	32	26	20	20	20	20	19	19	23	25	21	24	20	24	31	27	36	18	19	18
5	11.7	561	567	541	564	561	538	22	33	32	28	21	20	21	20	20	21	24	28	21	25	21	24	32	28	34	20	21	19
6	0.5	706	755	687	724	768	726	22	33	31	26	21	20	20	20	20	21	23	26	21	24	20	23	31	27	33	19	20	19
7	6.1	647	640	652	645	639	630	22	35	40	26	20	20	20	20	20	20	22	27	21	23	20	23	33	31	40	19	19	19
8	4.4	676	672	679	691	678	685	22	35	39	26	20	20	20	20	20	20	22	26	21	23	20	22	32	34	38	19	19	19
9	5.1	645	612	643	639	613	617	22	33	40	26	20	20	21	20	20	20	22	27	22	23	20	22	32	35	40	19	19	19
10	3.2	700	700	693	709	702	699	23	34	37	27	21	21	22	21	22	22	23	28	22	24	21	23	32	35	36	20	19	19
11	3.6	795	821	779	827	834	795	22	32	37	26	21	21	23	21	22	22	24	28	23	24	22	23	34	36	39	19	19	20
12	-2.8	792	781	778	801	785	782	22	31	36	25	21	22	23	21	23	22	25	29	24	25	23	24	34	36	38	19	20	20
13	3.4	758	741	752	758	745	739	22	29	34	24	21	23	25	22	24	22	26	31	26	26	24	24	35	35	37	19	20	21
14	3.6	721	685	718	710	688	686	22	29	33	24	21	24	26	22	25	23	28	32	27	27	25	24	37	34	36	19	20	22
15	4.9	729	712	726	732	718	715	23	29	34	24	21	25	28	23	27	24	29	34	29	28	26	25	39	35	37	19	21	23
16	4.8	735	718	735	739	727	724	25	29	34	25	22	26	30	24	28	25	31	36	31	30	28	25	40	35	39	19	22	24
17	4.5	755	733	749	755	746	744	27	28	35	25	23	27	32	25	30	26	33	38	33	31	29	26	42	37	40	19	22	26
18	4	771	746	763	772	756	762	27	28	35	26	24	28	34	27	31	27	34	39	35	33	31	27	43	38	40	20	23	27
19	3.3	783	758	776	789	764	774	27	28	35	27	24	30	37	28	33	28	36	41	37	34	32	28	45	39	42	20	24	29
20	4.6	784	762	784	789	777	782	28	28	35	28	25	31	39	29	34	29	38	43	39	36	34	29	45	41	44	20	25	31
21	4.3	786	771	787	799	785	789	28	29	35	29	26	32	41	31	35	31	39	44	40	37	36	30	46	43	44	20	26	32
22	4.8	795	775	791	805	790	794	29	30	36	30	27	33	43	32	37	32	41	46	42	39	37	31	47	44	45	21	27	34
23	4.4	800	785	803	814	797	806	30	31	41	32	28	35	45	34	38	33	42	47	44	40	39	32	49	45	48	21	27	35
24	4.4	808	790	809	816	807	809	30	32	39	32	29	36	47	35	40	35	44	48	45	42	41	33	49	45	50	21	28	37
25	4.7	817	798	816	823	812	816	31	34	39	32	30	38	49	37	41	36	45	50	47	43	42	34	50	47	51	22	29	39
26	4.4	815	805	823	831	817	822	31	34	38	35	30	39	51	38	43	38	47	51	49	45	44	35	51	47	53	22	30	40
27	4.7	824	808	826	830	821	826	32	36	40	35	31	41	54	40	44	39	49	53	50	46	46	36	52	47	54	23	31	42
28	4.4	826	812	834	833	825	826	33	38	41	35	32	42	56	42	46	41	50	54	52	48	47	36	53	47	56	24	32	43
29	3.7	838	819	836	845	830	832	34	38	40	36	32	44	58	43	47	42	52	56	53	50	49	37	56	47	57	24	33	44
30	4.5	830	819	838	840	833	833	36	39	41	37	32	45	60	45	49	44	54	57	55	51	50	38	57	48	58	25	34	46
31	4.3	837	824	844	844	837	839	37	39	41	37	32	47	62	46	51	46	55	59	56	53	52	38	58	49	58	26	35	47
32	5	845	834	848	854	850	845	38	41	45	37	33	49	63	48	53	47	57	60	58	55	54	39	60	49	59	28	36	48
33	4.9	855	842	858	863	857	852	39	42	44	38	34	50	65	50	55	49	59	62	60	57	56	40	60	50	59	29	38	49
34	4.6	863	850	864	870	864	862	40	43	44	39	35	52	67	51	56	51	60	64	61	59	58	41	61	50	59	31	39	50

The legal validity of this report can only be claimed on presentation of the complete report.
This is an electronic copy of the report which is uncontrolled if printed.



Time	Chan 0	Chan 1	Chan 2	Chan 3	Chan 4	Chan 5	Chan 6	Chan 7	Chan 10	Chan 12	Chan 13	Chan 14	Chan 15	Chan 16	Chan 17	Chan 18	Chan 19	Chan n 20	Chan 21	Chan 22	Chan 23	Chan 24	Chan 25	Chan 26	Chan 27	Chan 28	Chan 29	Chan 30	Chan 31	
min	Pa	°C	°C	°C	°C	°C	°C	°C	°C	°C	°C	°C	°C	°C	°C	°C	°C	°C	°C	°C	°C	°C	°C	°C	°C	°C	°C	°C	°C	
35	5.2	870	860	876	878	872	873	41	44	45	39	36	54	69	53	58	53	62	66	63	61	60	42	61	51	60	32	40	51	
36	5.1	878	865	879	884	880	880	43	45	44	40	37	56	70	55	60	56	64	68	64	63	62	43	61	51	61	34	41	52	
37	4.8	882	871	884	890	886	883	43	46	45	41	38	58	72	57	62	58	65	69	66	66	64	44	61	51	61	36	42	53	
38	4.7	884	873	888	891	885	888	43	47	45	41	39	59	74	59	64	60	67	71	68	67	66	45	60	51	61	39	44	54	
39	4.7	883	873	892	891	885	882	44	48	45	42	39	61	75	60	66	62	68	73	69	69	68	45	60	52	61	41	45	55	
40	4.7	883	874	889	888	884	886	44	49	46	43	40	63	76	62	67	64	70	74	71	71	70	46	60	51	61	42	46	56	
41	4.6	882	872	891	888	883	885	44	51	46	43	40	65	78	63	69	67	72	76	72	73	72	47	60	51	61	43	47	57	
42	4.7	881	871	889	885	881	880	45	53	46	44	40	67	79	65	71	69	73	77	74	75	74	47	60	51	61	45	48	59	
43	5.2	888	881	893	894	891	887	45	58	47	45	41	68	81	67	72	71	75	79	76	77	75	48	60	51	60	46	50	60	
44	4.4	900	892	901	905	901	896	45	66	49	46	41	70	82	68	74	74	77	82	77	79	77	49	60	51	60	47	51	61	
45	5.1	907	901	911	914	908	911	45	73	51	48	43	72	83	70	75	76	79	87	79	81	79	49	60	51	62	49	53	62	
46	4.8	915	906	916	921	916	914	46	138	57	49	42	74	84	72	76	78	80	89	81	83	80	49	60	51	61	50	54	63	
47	5	918	912	924	920	919	920	34	82	31	25	32	37	40	51	51	21	56	36	51	63	56	49	59	51	61	51	55	64	
48	4.6	919	915	927	924	923	920	26	34	23	21	25	23	25	35	34	23	39	23	35	41	38	51	58	52	61	53	57	65	
49	4.2	921	918	931	927	925	921	22	24	20	20	23	21	22	29	26	17	29	20	23	31	30	50	58	52	61	54	58	66	
50	4.9	924	922	935	930	928	930	21	32	19	20	23	21	21	27	24	15	26	20	21	27	27	51	57	51	61	55	60	68	
51	5	926	926	937	935	932	935	21	27	19	20	22	20	21	26	23	19	24	20	21	25	26	52	57	51	60	56	61	69	
52	4.9	926	926	940	937	933	934	20	24	19	20	23	20	21	25	22	19	24	20	21	24	26	53	56	52	61	56	63	70	
53	4.6	930	927	939	939	935	938	20	24	19	20	23	20	21	25	22	17	23	20	21	23	25	53	56	52	60	56	64	71	
54	4.5	937	930	939	942	938	940	20	23	19	20	23	20	21	25	22	14	23	20	21	23	25	53	57	51	60	56	66	72	
55	4.5	938	931	944	944	938	938	20	23	19	20	23	21	20	25	21	24	22	20	21	22	24	53	56	51	61	56	67	74	
56	4.6	949	936	945	949	943	946	20	22	22	19	23	20	20	24	21	7	22	20	20	22	24	53	56	51	61	57	68	75	
57	4.5	959	940	949	955	947	948	19	22	19	19	23	20	20	24	20	23	21	20	19	21	24	53	56	52	62	57	69	76	
58	3.6	968	937	948	955	941	945	19	22	19	19	24	20	20	24	20	23	21	20	19	21	23	53	57	52	62	57	70	77	
59	3.7	975	938	948	955	943	946	19	22	19	19	24	20	20	24	20	23	21	20	19	21	23	53	57	52	63	56	72	79	
60	3.9	981	942	951	962	946	949	19	22	19	19	24	20	20	24	20	23	21	20	19	21	23	52	58	51	64	57	73	80	
61	3.4	978	941	952	965	943	948	19	22	19	19	25	20	20	24	19	23	21	20	19	21	23	52	58	51	65	57	74	81	
62	3.3	981	943	952	972	944	948	19	22	19	20	25	20	20	24	19	23	21	20	19	21	24	52	59	51	66	57	74	77	
63	2.5	977	949	954	978	947	950	19	22	19	20	25	20	20	24	20	23	21	20	19	21	24	53	59	51	67	58	75	72	
64	4.8	976	945	958	986	948	949	19	21	19	20	25	20	20	24	20	23	21	20	19	21	24	53	59	52	70	60	76	70	
65	4.6	971	935	952	980	939	943	19	21	19	20	26	20	20	24	20	23	21	20	19	21	24	54	59	53	73	61	77	69	
66	4.8	958	924	944	974	931	930	19	21	19	20	26	20	20	25	20	24	21	20	19	21	24	54	60	53	75	62	78	70	
67	4.5	962	942	950	985	948	949	19	21	19	20	26	20	20	25	20	24	21	20	19	20	24	56	60	54	79	64	79	72	
68	3.4	973	958	969	999	967	973	19	21	19	20	26	20	20	25	20	24	21	20	19	20	24	55	60	54	82	64	80	75	
69	3.3	971	956	967	994	963	968	19	21	19	20	27	20	20	26	20	24	21	19	19	20	25	55	61	54	86	63	81	78	
70	4	967	954	966	985	961	970	19	21	19	20	28	20	20	26	20	25	21	20	20	20	25	56	61	55	93	64	81	80	
71	5.4	964	956	968	978	964	974	20	21	19	20	28	20	20	26	20	25	21	20	20	20	25	57	62	57	173	66	82	83	
72	-1.5	996	1027	1015	993	1018	1039	20	21	21	22	26	21	21	26	21	25	21	21	21	21	22	26	30	31	28	51	29	30	51

The legal validity of this report can only be claimed on presentation of the complete report.
This is an electronic copy of the report which is uncontrolled if printed.



Time min	Chan 32 °C	Chan 33 °C	Chan 34 °C	Chan 35 °C	Chan 36 °C	Chan 37 °C	Chan 38 °C	Chan 39 °C	Chan 40 kw/m ²	Chan 41 kw/m ²	Chan 42 °C
0	19	19	19	19	18	18	19	18	0.3	0.3	19
1	20	20	19	21	21	19	19	19	0.3	0.3	19
2	20	19	19	24	26	20	20	19	0.3	0.3	19
3	20	19	19	24	24	20	20	19	0.3	0.3	19
4	19	19	19	22	23	20	20	19	0.3	0.3	19
5	20	20	21	24	23	20	20	19	0.3	0.3	19
6	20	20	20	23	23	20	20	20	0.3	0.3	19
7	20	20	20	22	22	20	20	19	0.3	0.2	19
8	20	20	20	22	22	20	20	19	0.3	0.3	19
9	20	20	20	21	22	20	20	19	0.3	0.3	19
10	20	20	21	21	22	20	20	20	0.3	0.2	19
11	20	20	20	21	22	20	20	20	0.3	0.3	19
12	20	20	20	21	22	21	20	20	0.3	0.3	19
13	20	20	20	22	22	21	21	20	0.3	0.3	19
14	20	20	20	22	22	22	22	20	0.3	0.3	19
15	21	21	21	23	23	23	23	21	0.3	0.3	19
16	22	21	22	24	24	24	24	22	0.3	0.3	19
17	22	22	22	25	25	25	26	22	0.3	0.2	19
18	23	22	23	26	26	27	27	23	0.3	0.3	19
19	24	23	24	29	27	28	29	25	0.3	0.3	19
20	25	24	25	29	29	30	31	26	0.3	0.3	19
21	25	24	26	30	30	31	32	27	0.3	0.3	19
22	26	25	27	31	31	33	34	28	0.3	0.3	19
23	27	26	28	32	33	34	35	29	0.3	0.3	19
24	28	26	29	33	34	35	37	30	0.3	0.3	19
25	29	27	31	34	35	37	39	32	0.3	0.4	19
26	30	28	32	35	36	38	40	33	0.3	0.3	19
27	31	29	33	37	38	39	41	34	0.3	0.4	19
28	32	30	34	38	39	40	43	35	0.3	0.4	19
29	32	30	35	39	40	42	44	36	0.3	0.4	19
30	33	31	37	40	41	43	45	37	0.4	0.3	19
31	34	32	38	41	42	44	47	38	0.4	0.3	19
32	36	33	39	42	43	45	48	40	0.3	0.3	19
33	36	34	40	43	45	46	49	41	0.4	0.4	19
34	38	35	41	44	46	47	50	42	0.3	0.4	19
35	39	36	43	45	47	49	52	43	0.4	0.4	19
36	40	37	44	46	48	50	53	45	0.4	0.3	19
37	41	38	45	47	49	51	54	46	0.4	0.4	19
38	42	40	46	48	50	52	55	47	0.4	0.3	19
39	43	41	47	49	52	53	56	48	0.4	0.4	19
40	44	42	48	50	53	54	57	49	0.3	0.3	19

*The legal validity of this report can only be claimed on presentation of the complete report.
This is an electronic copy of the report which is uncontrolled if printed.*

Time	Chan 32	Chan 33	Chan 34	Chan 35	Chan 36	Chan 37	Chan 38	Chan 39	Chan 40	Chan 41	Chan 42
min	°C	°C	°C	°C	°C	°C	°C	°C	kw/m ²	kw/m ²	°C
41	46	43	49	51	54	56	58	51	0.4	0.4	19
42	47	45	50	53	55	57	59	52	0.4	0.4	19
43	48	46	52	54	56	58	60	53	0.4	0.4	19
44	49	47	53	55	57	59	61	54	0.4	0.3	19
45	50	49	54	56	59	60	62	55	0.4	0.4	19
46	52	50	54	57	60	61	63	56	0.5	58.2	19
47	53	51	55	58	61	62	64	56	85.4	51.5	19
48	54	52	56	60	62	64	65	57	54.4	63.9	19
49	56	27	57	61	63	65	66	59	52.7	63	19
50	57	26	58	62	64	66	67	60	52.9	64.5	19
51	59	26	60	63	65	67	68	61	53.1	66.7	19
52	60	26	61	65	66	68	69	62	0.3	68.2	19
53	62	27	62	66	67	69	70	63	34.8	69.3	19
54	63	27	63	67	68	70	71	65	107.1	69.2	19
55	65	27	65	68	69	71	72	66	65.4	67.9	19
56	66	27	66	69	70	72	73	67	59.2	70.7	19
57	67	27	67	70	71	72	75	68	58.9	71.2	19
58	68	29	68	71	72	73	76	69	28.1	70.7	19
59	70	31	70	72	73	74	77	70	57.9	69	19
60	71	30	71	73	74	75	78	71	43.1	69.2	19
61	72	32	72	74	75	75	79	72	37	69.4	19
62	72	51	73	75	76	76	81	72	30.9	69.6	19
63	73	43	73	75	77	77	82	73	41.1	66.1	19
64	74	72	74	77	78	78	83	75	35.5	74.2	19
65	75	39	75	78	79	78	86	76	35.7	71.8	19
66	75	31	76	79	80	79	87	77	37.8	67.9	19
67	76	41	77	80	80	80	89	79	42.6	67.5	19
68	77	37	78	81	81	80	89	80	41.2	0.5	19
69	78	40	79	82	82	81	90	80	38.7	0	19
70	79	78	81	83	83	81	91	82	24.1	-3.5	19
71	80	37	80	83	83	82	97	83	1.9	9.9	19
72	40	41	58	34	63	62	70	60	-262.2	2.6	19

*The legal validity of this report can only be claimed on presentation of the complete report.
This is an electronic copy of the report which is uncontrolled if printed.*